



# Product Specification

AU OPTRONICS CORPORATION

( ) Preliminary Specifications

( V ) Final Specifications

<b>Module</b>	13.3" WXGA Color TFT-LCD
<b>Model Name</b>	B133EW03 V2
<b>Note</b> (  )	<i>LED Backlight without driving circuit design</i>

<b>Customer</b>	<b>Date</b>
<b>Checked &amp; Approved by</b>	<b>Date</b>
_____	_____
<p>Note: This Specification is subject to change without notice.</p>	

<b>Approved by</b>	<b>Date</b>
Howard Lee	<u>11/24/2008</u>
<b>Prepared by</b>	
Wei Hsiang Lo	<u>11/24/2008</u>
<p><b>NBBU Marketing Division / AU Optronics corporation</b></p>	



## Contents

<b>1. Handling Precautions</b> .....	<b>4</b>
<b>2. General Description</b> .....	<b>5</b>
2.1 General Specification .....	5
2.2 Optical Characteristics .....	6
<b>3. Functional Block Diagram</b> .....	<b>11</b>
<b>4. Absolute Maximum Ratings</b> .....	<b>12</b>
4.1 Absolute Ratings of TFT LCD Module.....	12
4.2 Absolute Ratings of Environment .....	12
<b>5. Electrical characteristics</b> .....	<b>13</b>
5.1 TFT LCD Module.....	13
5.2 Backlight Unit.....	15
<b>6. Signal Characteristic</b> .....	<b>16</b>
6.1 Pixel Format Image.....	16
6.2 The input data format.....	17
6.3 Signal Description/Pin Assignment .....	18
6.4 Interface Timing.....	21
<b>7. Connector Description</b> .....	<b>24</b>
7.1 TFT LCD Module.....	24
<b>8. LED Driving Specification</b> .....	<b>25</b>
8.1 Connector Description .....	25
8.2 Pin Assignment .....	25
<b>9. Vibration and Shock Test</b> .....	<b>26</b>
9.1 Vibration Test .....	26
9.2 Shock Test Spec: .....	26
<b>10. Reliability</b> .....	<b>27</b>
<b>11. Mechanical Characteristics</b> .....	<b>28</b>
11.1 LCM Outline Dimension .....	28
<b>12. Shipping and Package</b> .....	<b>30</b>
12.1 Shipping Label Format .....	30
12.2 Carton package.....	31
11.3 Shipping package of palletizing sequence .....	32



# Product Specification

AU OPTRONICS CORPORATION

## Record of Revision

Version and Date	Page	Old description	New Description	Remark
0.1 2008/11/24	All	First Edition for Customer		

## 1. Handling Precautions

- 1) Since front polarizer is easily damaged, pay attention not to scratch it.
- 2) Be sure to turn off power supply when inserting or disconnecting from input connector.
- 3) Wipe off water drop immediately. Long contact with water may cause discoloration or spots.
- 4) When the panel surface is soiled, wipe it with absorbent cotton or other soft cloth.
- 5) Since the panel is made of glass, it may break or crack if dropped or bumped on hard surface.
- 6) Since CMOS LSI is used in this module, take care of static electricity and insure human earth when handling.
- 7) Do not open nor modify the Module Assembly.
- 8) Do not press the reflector sheet at the back of the module to any directions.
- 9) At the insertion or removal of the Signal Interface Connector, be sure not to rotate nor tilt the Interface Connector of the TFT Module.
- 11) After installation of the TFT Module into an enclosure (Notebook PC Bezel, for example), do not twist nor bend the TFT Module even momentary. At designing the enclosure, it should be taken into consideration that no bending/twisting forces are applied to the TFT Module from outside. Otherwise the TFT Module may be damaged.
- 12) Small amount of materials having no flammability grade is used in the LCD module. The LCD module should be supplied by power complied with requirements of Limited Power Source (IEC60950 or UL1950), or be applied exemption.
- 13) **Disconnecting power supply before handling LCD modules, it can prevent electric shock, DO NOT TOUCH the electrode parts, cables, connectors and LED circuit part of TFT module that a LED light bar build in as a light source of back light unit. It can prevent electrostatic breakdown.**



## 2. General Description

B133EW03 V2 is a Color Active Matrix Liquid Crystal Display composed of a TFT LCD panel, a driver circuit, and LED backlight system. The screen format is intended to support the WXGA (1280(H) x 800(V)) screen and 262k colors (RGB 6-bits data driver) with LED backlight driving circuit. All input signals are LVDS interface compatible.

B133EW03 V2 is designed for a display unit of notebook style personal computer and industrial machine.

### 2.1 General Specification

The following items are characteristics summary on the table at 25 °C condition:

Items	Unit	Specifications			
Screen Diagonal	[mm]	337.8 (13.3W")			
Active Area	[mm]	286.08 X 178.8			
Pixels H x V		1280x3(RGB) x 800			
Pixel Pitch	[mm]	0.2235X0.2235			
Pixel Format		R.G.B. Vertical Stripe			
Display Mode		Normally White			
White Luminance (ILED=16mA) (Note: ILED is LED current)	[cd/m <sup>2</sup> ]	280 typ. (5 points average) 250 min. (5 points average)			
Luminance Uniformity		1.25 max. (5 points)			
Contrast Ratio		500 typ ,			
Response Time	[ms]	20 typ / 25 Max			
Nominal Input Voltage VDD	[Volt]	+3.3 typ.			
Power Consumption	[Watt]	4.2 typ. (Include Logic and Blu power)			
Weight	[Grams]	219 max.			
Physical Size	[mm]		L	W	T
		Max	-	-	3.045
		Typ	297.15	203.15	2.86
		Min	-	-	-
Electrical Interface		1 channel LVDS			
Surface Treatment		Glare, Hardness 3H, Reflection ~0.5%			
Support Color		262K colors ( RGB 6-bit )			



# Product Specification

AU OPTRONICS CORPORATION

Temperature Range Operating	[°C]	0 to +50
Storage (Non-Operating)	[°C]	-25 to +65
RoHS Compliance		RoHS Compliance

## 2.2 Optical Characteristics

The optical characteristics are measured under stable conditions at 25°C (Room Temperature) :

Item	Unit	Conditions	Min.	Typ.	Max.	Note
<b>White Luminance</b> (I <sub>LED</sub> =16mA)	[cd/m <sup>2</sup> ]	<b>5 points average</b>	<b>250</b>	<b>280</b>	-	1, 4, 5.
<b>Viewing Angle</b>	[degree] [degree]	<b>Horizontal</b> <b>(Right)</b>	-	<b>75</b>	-	4, 9
		<b>CR = 10 (Left)</b>	-	<b>75</b>	-	
	[degree] [degree]	<b>Vertical</b> <b>(Upper)</b>	-	<b>60</b>	-	
		<b>CR = 10 (Lower)</b>	-	<b>60</b>	-	
<b>Luminance Uniformity</b>		<b>5 Points</b>	-	-	<b>1.25</b>	1, 3, 4
<b>Luminance Uniformity</b>		<b>13 Points</b>	-	-	<b>1.50</b>	2, 3, 4
<b>CR: Contrast Ratio</b>		<b>DCR:Off</b>	<b>300</b>	<b>500</b>	-	4, 6
<b>Cross talk</b>	%				<b>4</b>	4, 7
<b>Response Time</b>	[msec]	<b>Rising</b>	-	-	-	4, 8
	[msec]	<b>Falling</b>	-	-	-	
	[msec]	<b>Rising + Falling</b>	-	<b>20</b>	<b>25</b>	
<b>Chromaticity of color Coordinates</b> (CIE 1931)		<b>Red x</b>	<b>0.575</b>	<b>0.600</b>	<b>0.625</b>	4, 9
		<b>Red y</b>	<b>0.325</b>	<b>0.345</b>	<b>0.365</b>	
		<b>Green x</b>	<b>0.300</b>	<b>0.320</b>	<b>0.340</b>	
		<b>Green y</b>	<b>0.530</b>	<b>0.555</b>	<b>0.580</b>	
		<b>Blue x</b>	<b>0.130</b>	<b>0.150</b>	<b>0.170</b>	
		<b>Blue y</b>	<b>0.100</b>	<b>0.120</b>	<b>0.130</b>	
		<b>White x</b>	<b>0.263</b>	<b>0.313</b>	<b>0.363</b>	
		<b>White y</b>	<b>0.279</b>	<b>0.329</b>	<b>0.379</b>	

**Note 1:** 5 points position (Ref: Active area)

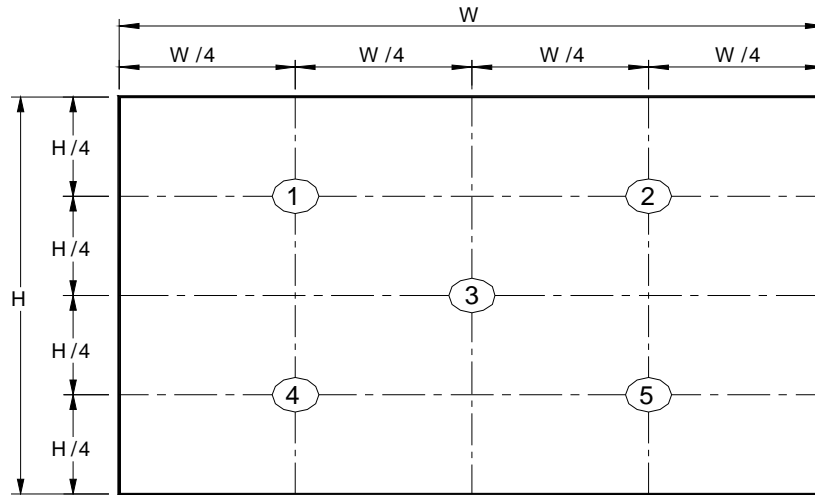

**Note 2:** 13 points position (Ref: Active area)

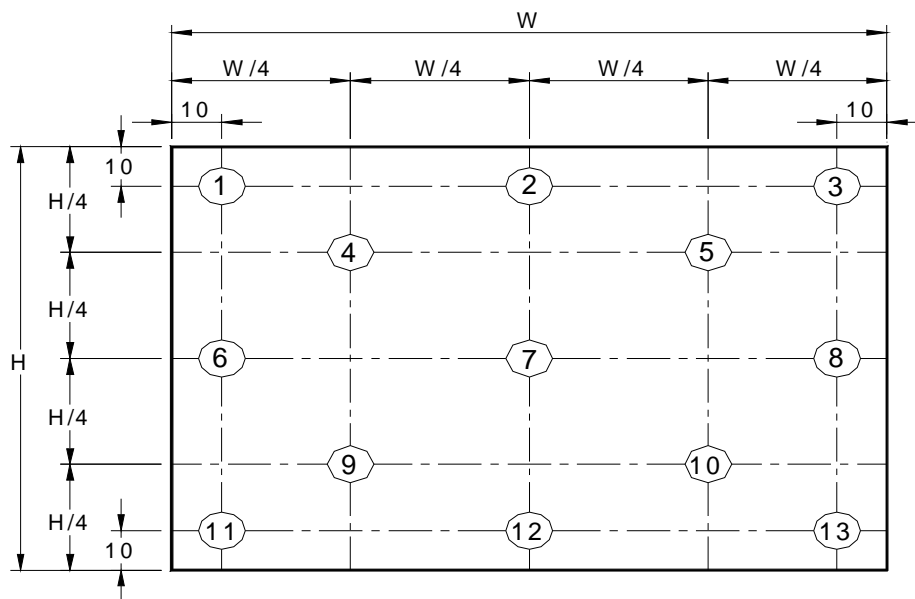

**Note 3:** The luminance uniformity of 5 or 13 points is defined by dividing the maximum luminance values by the minimum test point luminance

$$\delta_{w5} = \frac{\text{Maximum Brightness of five points}}{\text{Minimum Brightness of five points}}$$

$$\delta_{w13} = \frac{\text{Maximum Brightness of thirteen points}}{\text{Minimum Brightness of thirteen points}}$$

**Note 4:** Measurement method

The LCD module should be stabilized at given temperature for 30 minutes to avoid abrupt temperature change during measuring. In order to stabilize the luminance, the measurement should be executed after

lighting Backlight for 30 minutes in a stable, windless and dark room.

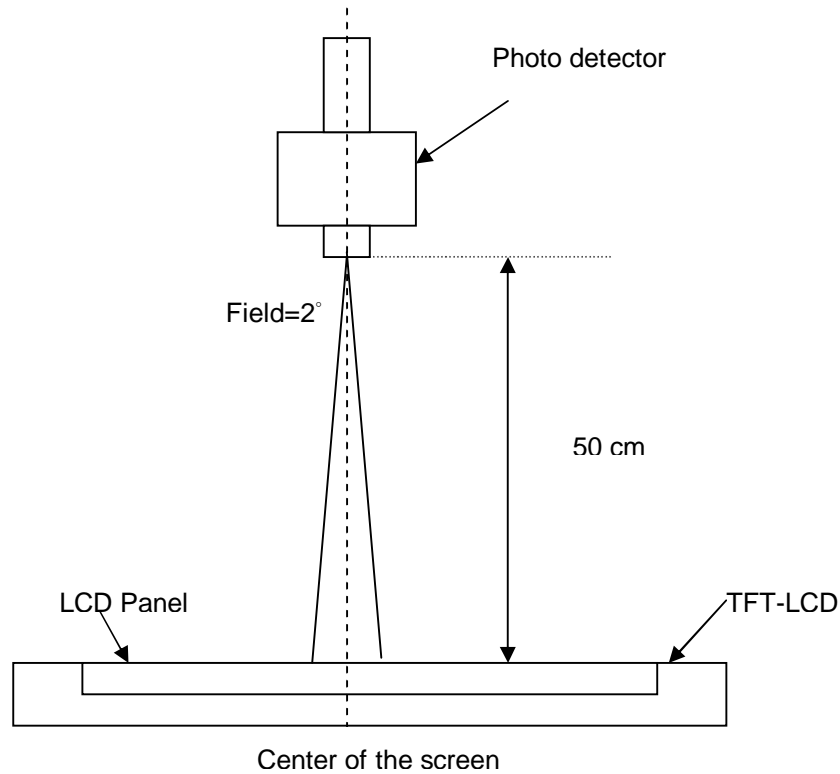

**Note 5 :** Definition of Average Luminance of White ( $Y_L$ ):

Measure the luminance of gray level 63 at 5 points ·  $Y_L = [L(1) + L(2) + L(3) + L(4) + L(5)] / 5$

$L(x)$  is corresponding to the luminance of the point X at Figure in Note (1).

**Note 6 :** Definition of contrast ratio:

Contrast ratio is calculated with the following formula.

$$\text{Contrast ratio (CR)} = \frac{\text{Brightness on the "White" state}}{\text{Brightness on the "Black" state}}$$

**Note 7 :** Definition of Cross Talk (CT)

$$CT = |Y_B - Y_A| / Y_A \times 100 (\%)$$

Where

$Y_A$  = Luminance of measured location without gray level 0 pattern ( $\text{cd}/\text{m}^2$ )

$Y_B$  = Luminance of measured location with gray level 0 pattern ( $\text{cd}/\text{m}^2$ )



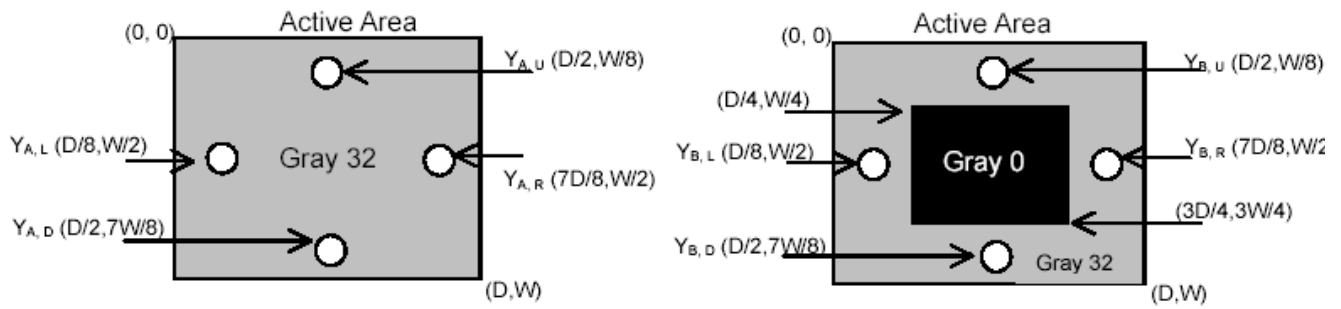

**Note 8:** Definition of response time:

The output signals of BM-7 or equivalent are measured when the input signals are changed from "Black" to "White" (falling time) and from "White" to "Black" (rising time), respectively. The response time interval between the 10% and 90% of amplitudes. Refer to figure as below.

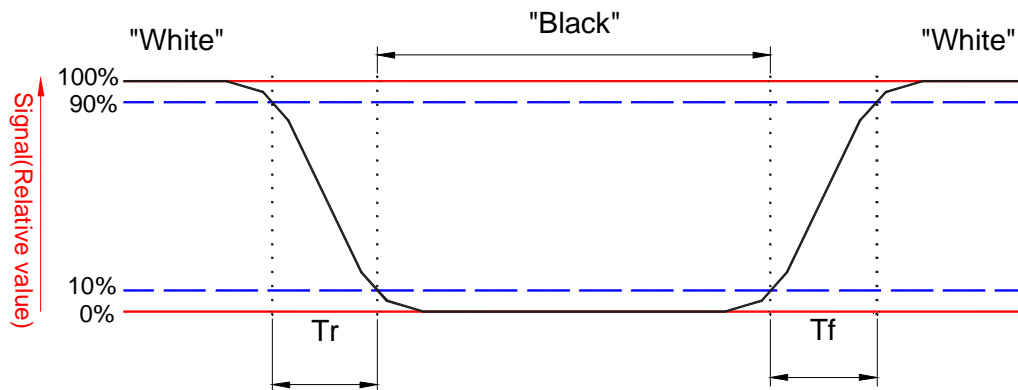

**Note 9.** Definition of viewing angle

Viewing angle is the measurement of contrast ratio  $\geq 10$ , at the screen center, over a  $180^\circ$  horizontal and  $180^\circ$  vertical range (off-normal viewing angles). The  $180^\circ$  viewing angle range is broken down as follows;  $90^\circ$  ( $\theta$ ) horizontal left and right and  $90^\circ$  ( $\phi$ ) vertical, high (up) and low (down). The measurement direction is typically perpendicular to the display surface with the screen rotated about its center to develop the desired measurement viewing angle.

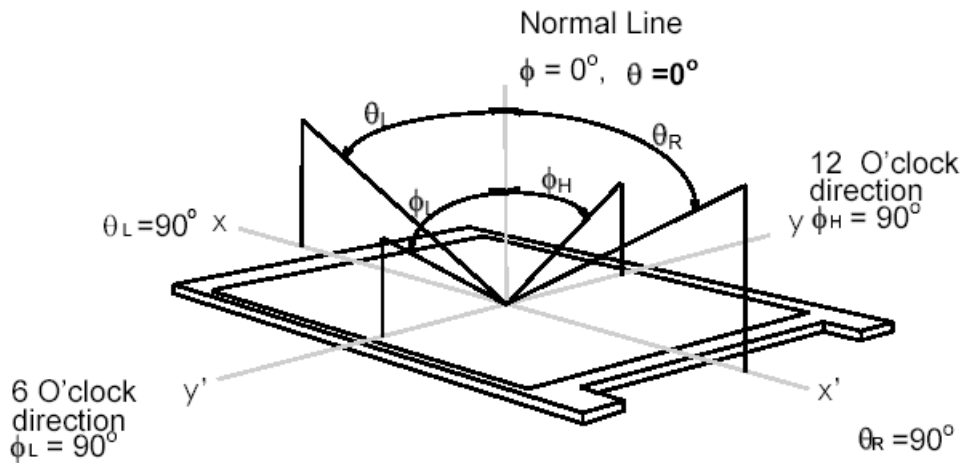

## 3. Functional Block Diagram

The following diagram shows the functional block of the 13.3 inches wide Color TFT/LCD Module:

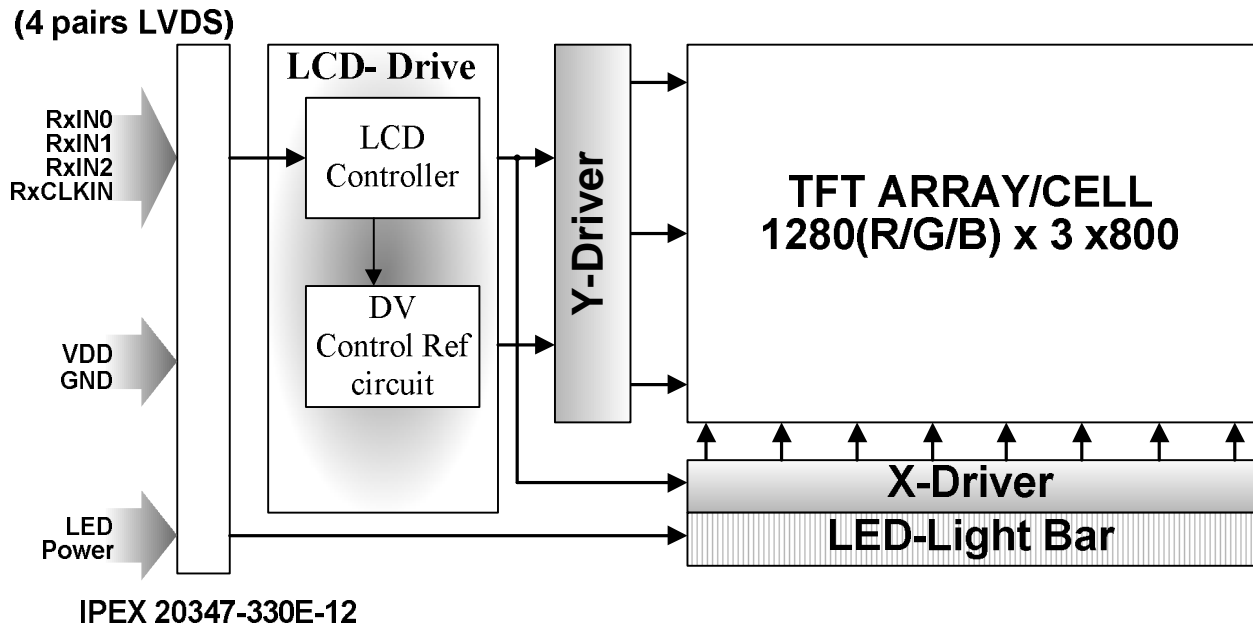

## 4. Absolute Maximum Ratings

An absolute maximum rating of the module is as following:

### 4.1 Absolute Ratings of TFT LCD Module

Item	Symbol	Min	Max	Unit	Conditions
Logic/LCD Drive	Vin	-0.3	+4.0	[Volt]	Note 1,2

### 4.2 Absolute Ratings of Environment

Item	Symbol	Min	Max	Unit	Conditions
Operating Temperature	TOP	0	+50	[°C]	Note 4
Operation Humidity	HOP	10	90	[%RH]	Note 4
Storage Temperature	TST	-25	+65	[°C]	Note 4
Storage Humidity	HST	10	90	[%RH]	Note 4

Note 1: At Ta (25°C )

Note 2: Permanent damage to the device may occur if exceed maximum values

Note 3: LED specification refer to section 5.2

**Note 4: For quality performance, please refer to AUO IIS (Incoming Inspection Standard).**

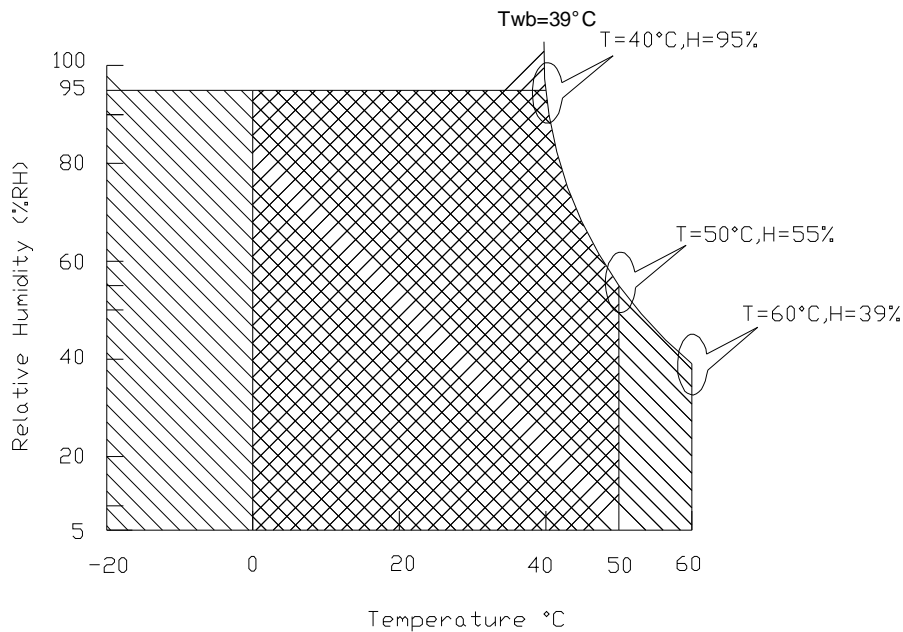

Operating Range 

Storage Range

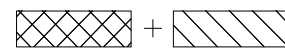

## 5. Electrical characteristics

### 5.1 TFT LCD Module

#### 5.1.1 Power Specification

Input power specifications are as follows;

Symble	Parameter	Min	Typ	Max	Units	Note
VDD	Logic/LCD Drive Voltage	3.0	3.3	3.6	[Volt]	
PDD	VDD Power	-	-	0.90	[Watt]	Note 1/2
IDD	IDD Current	-	220	250	[mA]	Note 1/2
IRush	Inrush Current	-	-	1500	[mA]	Note 3
VDDrp	Allowable Logic/LCD Drive Ripple Voltage	-	-	100	[mV] p-p	

Note 1 : Maximum Measurement Condition : Black Pattern

Note 2 : Typical Measurement Condition: Mosaic Pattern

Note 3 : Measure Condition

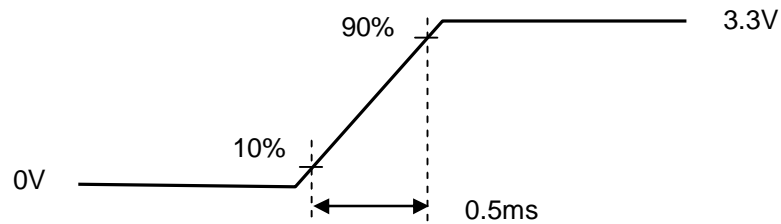
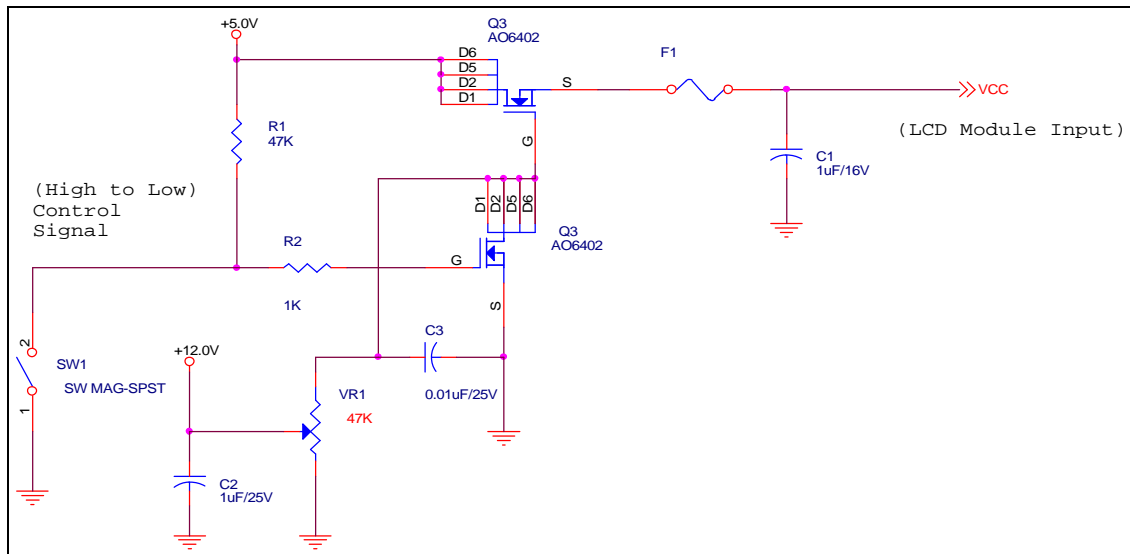

Vin rising time





## 5.2 Backlight Unit

LED Parameter guideline for LED driving selection

Parameter	Symbol	Min	Typ	Max	Units	Condition
LED Forward Voltage	$V_F$	3.0	3.2	3.3	[Volt]	( $T_a=25^\circ\text{C}$ )
LED Forward Current	$I_F$		16	30	[mA]	( $T_a=25^\circ\text{C}$ )
LED Power consumption	$P_{LED}$		2.76		[Watt]	( $T_a=25^\circ\text{C}$ ) Note 1
LED Life-Time	N/A	10,000	-	-	Hour	( $T_a=25^\circ\text{C}$ ) $I_F=16\text{ mA}$ Note 2

**Note 1:** Calculator value for reference  $P_{LED} = I_F \times V_F \times \text{LED}(\text{Qty})$

**Note 2:** The LED life-time define as the estimated time to 50% degradation of initial luminous.





## 6.2 The input data format

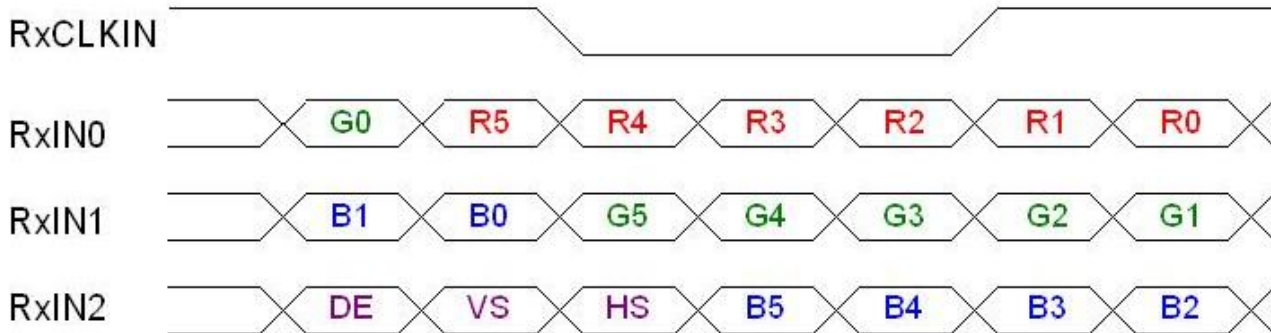

Signal Name	Description	
R5 R4 R3 R2 R1 R0	Red Data 5 (MSB) Red Data 4 Red Data 3 Red Data 2 Red Data 1 Red Data 0 (LSB)	Red-pixel Data Each red pixel's brightness data consists of these 6 bits pixel data.
G5 G4 G3 G2 G1 G0	Green Data 5 (MSB) Green Data 4 Green Data 3 Green Data 2 Green Data 1 Green Data 0 (LSB)	Green-pixel Data Each green pixel's brightness data consists of these 6 bits pixel data.
B5 B4 B3 B2 B1 B0	Blue Data 5 (MSB) Blue Data 4 Blue Data 3 Blue Data 2 Blue Data 1 Blue Data 0 (LSB)	Blue-pixel Data Each blue pixel's brightness data consists of these 6 bits pixel data.
RxCLKIN	Data Clock	The typical frequency is 68.9 MHz. The signal is used to strobe the pixel data and DE signals. All pixel data shall be valid at the falling edge when the DE signal is high.
DE	Display Timing	This signal is strobed at the falling edge of RxCLKIN. When the signal is high, the pixel data shall be valid to be displayed.
VS	Vertical Sync	The signal is synchronized to RxCLKIN .
HS	Horizontal Sync	The signal is synchronized to RxCLKIN .

Note: Output signals from any system shall be low or High-impedance state when VDD is off.

## 6.3 Integration Interface and Pin Assignment

LVDS is a differential signal technology for LCD interface and high speed data transfer device.

Pin	Signal	Description
1	GND	Ground
2	VDD	Power Supply (+3.3V)
3	VDD	Power Supply (+3.3V)
4	VDDedid	DDC Power (+3.3V)
5	AG_IN	Reserve for AUO aging test
6	CLKdeid	DDC clock
7	DATAedid	DDC Data
8	ORXIN0N	Differential data input
9	ORXIN0P	Differential data input
10	GND	Ground
11	ORXIN1N	Differential data input
12	ORXIN1P	Differential data input
13	GND	Ground
14	ORXIN2N	Differential data input
15	ORXIN2P	Differential data input
16	GND	Ground
17	CLOCKIN, N	Differential clock input
18	CLOCKIN, P	Differential clock input
19	GND	Ground
20	NC	No Connection
21	VOUT	LED Anode (Positive)
22	VOUT	LED Anode (Positive)
23	NC	No Connection
24	FB1	LED Cathode (Negative)
25	FB2	LED Cathode (Negative)
26	FB3	LED Cathode (Negative)
27	FB4	LED Cathode (Negative)
28	FB5	LED Cathode (Negative)
29	FB6	LED Cathode (Negative)
30	NC	No Connection



Note2: Input signals shall be low or High-impedance state when VDD is off.  
 internal circuit of LVDS inputs are as following.

The module uses a 100ohm resistor between positive and negative data lines of each receiver input

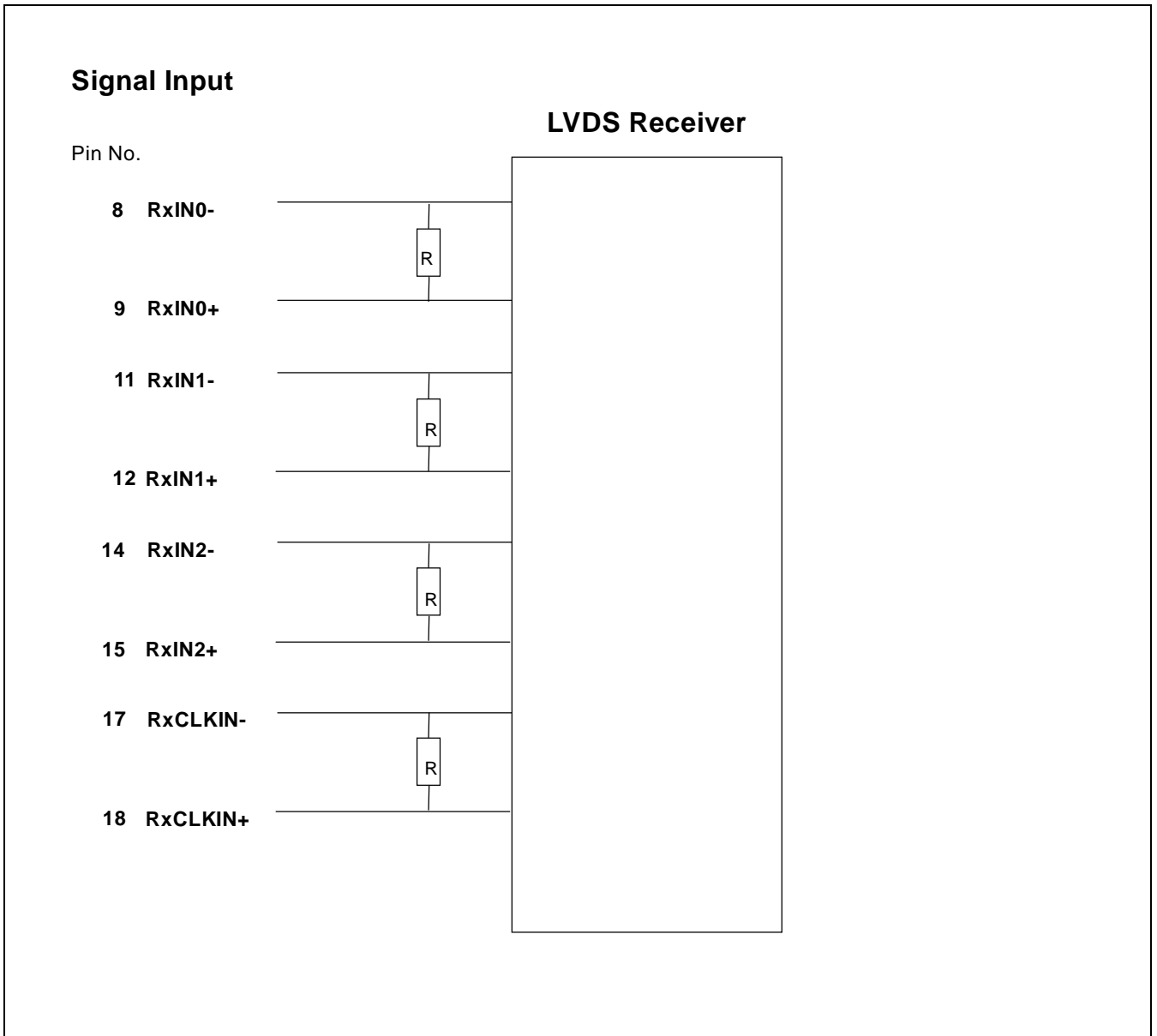

## 6.4 Interface Timing

### 6.4.1 Timing Characteristics

Basically, interface timings should match the 1280x800 /60Hz manufacturing guide line timing.

Signal	Parameter	Symbol	Min	Typ	Max	Unit	Note
D <sub>CLK</sub>	Clock Period	T <sub>C</sub>		14.06		ns	1
	Clock Frequency	f <sub>C</sub>		71.1	72	MHz	1/T <sub>C</sub>
DE							2
	Horizontal Period	T <sub>H</sub>	1440	1440		T <sub>C</sub>	
	Horizontal Blank Period	T <sub>ha</sub>	160	160		T <sub>C</sub>	f <sub>V</sub> =59.99 Hz, 3
	Vertical Period	T <sub>V</sub>	808	823		T <sub>H</sub>	
	Vertical Blank Period	T <sub>vwb</sub>	8	23		T <sub>H</sub>	
H <sub>sync</sub>	H <sub>sync</sub> Back Porch	H <sub>bp</sub>		80		T <sub>C</sub>	
	H <sub>sync</sub> Pulse Width	T <sub>WH</sub>		32		T <sub>C</sub>	
	H <sub>sync</sub> Front Porch	H <sub>fp</sub>		48		T <sub>C</sub>	
	Horizontal Active Period	T <sub>HD</sub>	1280	1280	1280	T <sub>C</sub>	Display Period
V <sub>sync</sub>	V <sub>sync</sub> Back Porch	V <sub>bp</sub>		14		T <sub>H</sub>	
	V <sub>sync</sub> Pulse Width	T <sub>WV</sub>		6		T <sub>H</sub>	
	V <sub>sync</sub> Front Porch	V <sub>fp</sub>		3		T <sub>H</sub>	
	Vertical Active Period	T <sub>VD</sub>	800	800	800	T <sub>H</sub>	Display Period

Note : DE mode only

## 6.4.2 Timing diagram

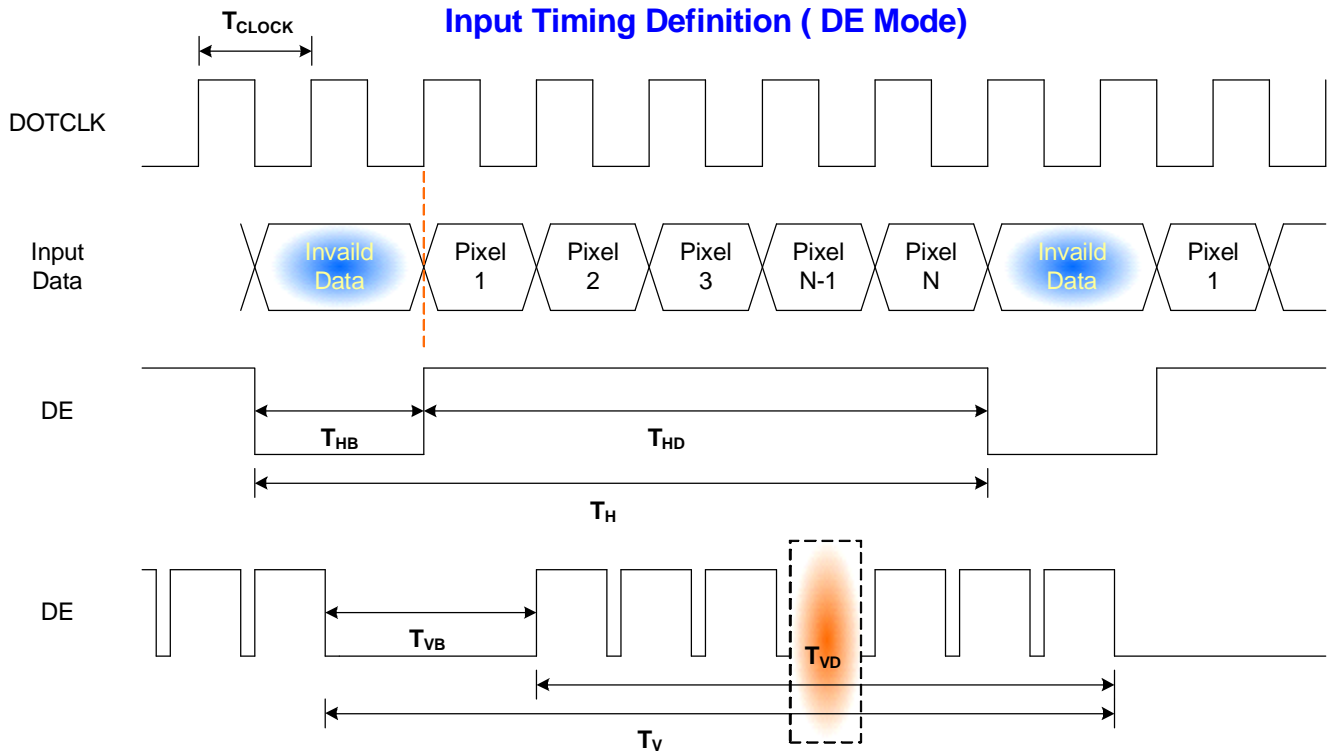

## 6.5 Power ON/OFF Sequence

LED on/off sequence is as follows. Interface signals are also shown in the chart.

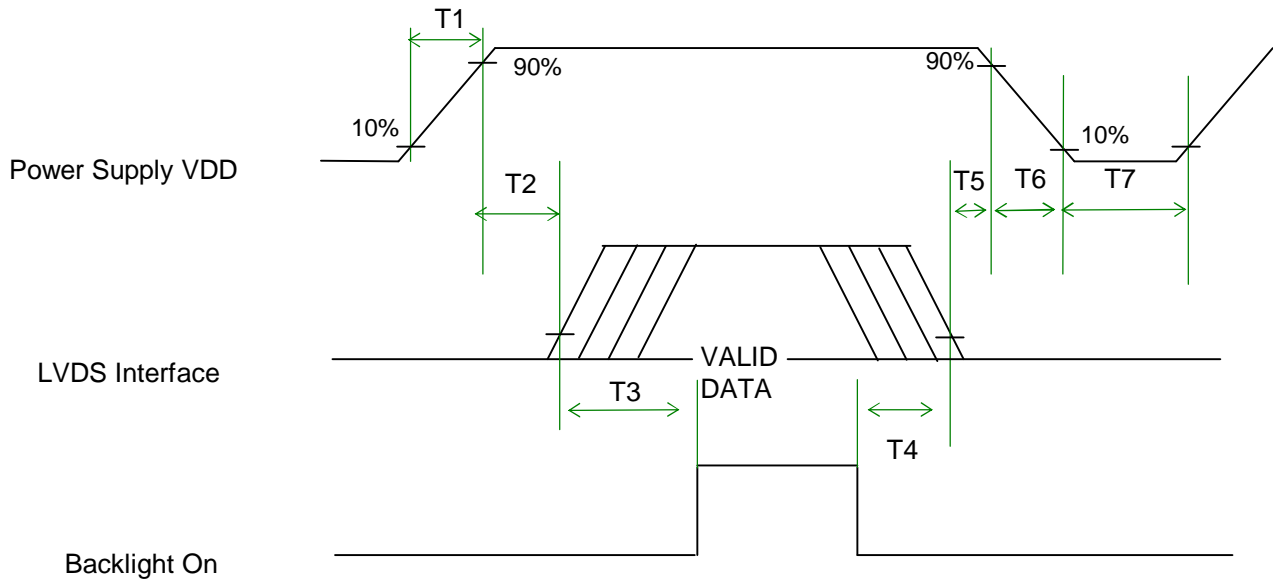

## Power Sequence Timing

Parameter	Value			Units
	Min.	Typ.	Max.	
T1	0.15	-	10	(ms)
T2	0	20	50	(ms)
T3	200	250	-	(ms)
T4	200	250	-	(ms)
T5	0	20	50	(ms)
T6	-	-	5	(ms)
T7	500	-	-	(ms)

Note: The duty of LED dimming signal should be more than 20% in T2 and T3.



## 7. Connector Description

Physical interface is described as for the connector on module.

These connectors are capable of accommodating the following signals and will be following components.

### 7.1 TFT LCD Module

<b>Connector Name / Designation</b>	<b>For Signal Connector</b>
Manufacturer	IPEX
Type / Part Number	<b>IPEX 20347-330E-12</b>
Mating Housing/Part Number	<b>IPEX 20345-030T-31</b>





## 8. LED Specification

### 8.1 General Information

LED Manufacturer	Nichia
LED Manufacture Assembly P/N	NNSW108-S1
Number of LEDs	54
LED bin	a6255, a6256, a6257, a6258, a6265, a6266, a6267, a6268, bj255, bj256, bj257, bj258, bj265, bj266, bj267, bj268
LED ranks	1800 mcd ~ 2400 mcd
LED brightness bin	50 mcd per bin
LED Vf	0.2V per bin
LED Forward Voltage Range for All 6 LED Series Lines	Max: 30.6 V

### 8.2 LED Connection

String	LED 1	LED 2	LED 3	LED 4	LED 5	LED 6	LED 7	LED 8	LED 9
1	1	7	13	19	25	31	37	43	49
2	2	8	14	20	26	32	38	44	50
3	3	9	15	21	27	33	39	45	51
4	4	10	16	22	28	34	40	46	52
5	5	11	17	23	29	35	41	47	53
6	6	12	18	24	30	36	42	48	54



## 9. Vibration and Shock Test

### 9.1 Vibration Test

**Test Spec:**

- I Test method: Non-Operation
- I Acceleration: 3.0 G
- I Frequency: 5 - 150Hz Random
- I Sweep: 30 Minutes each Axis (X, Y, Z)

### 9.2 Shock Test Spec:

**Test Spec:**

- I Test method: Non-Operation
- I Acceleration: 200 G , Half sine wave
- I Active time: 2 ms
- I Pulse: X,Y,Z .one time for each side

## 10. Reliability

Items	Required Condition	Note
Temperature Humidity Bias	Ta= 50°C , 90%RH, 240h	
High Temperature Operation	Ta= 50°C , RH, 300h	
Low Temperature Operation	Ta= 0°C , RH, 300h	
High Temperature Storage	Ta= 65°C , RH, 500h	
Low Temperature Storage	Ta= -25°C , RH, 500h	
Thermal Shock Test	Ta=-20°C to 60°C , Duration at 30 min, 100 cycles	
ESD	Contact : ±8 KV Air : ±15 KV	Note 1

**Note1:** According to EN 61000-4-2 , ESD class B: Some performance degradation allowed. No data lost  
 . Self-recoverable. No hardware failures.

**Remark:** MTBF (Excluding the LED): 30,000 hours with a confidence level 90%

## 11. Mechanical Characteristics

### 11.1 LCM Outline Dimension

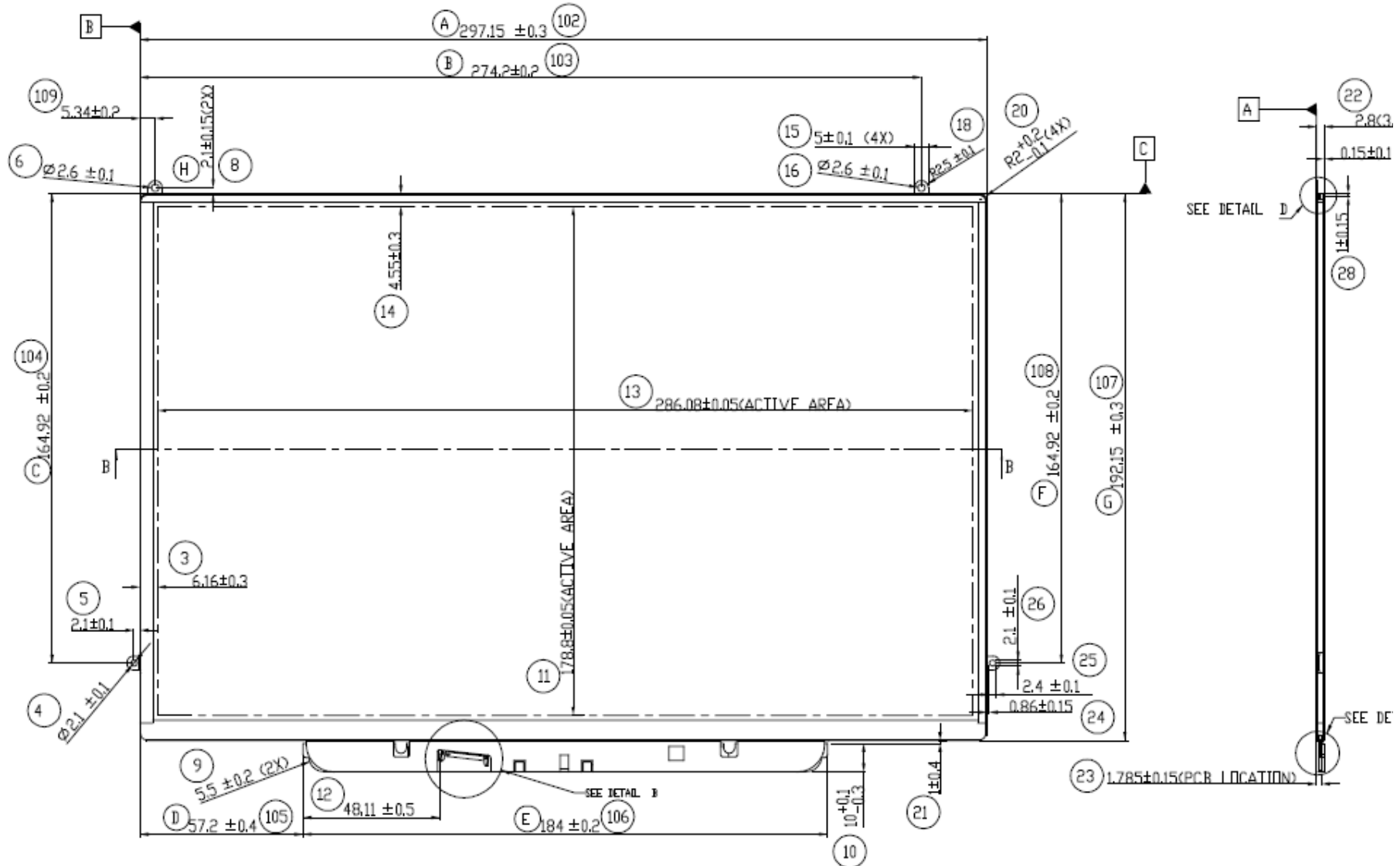

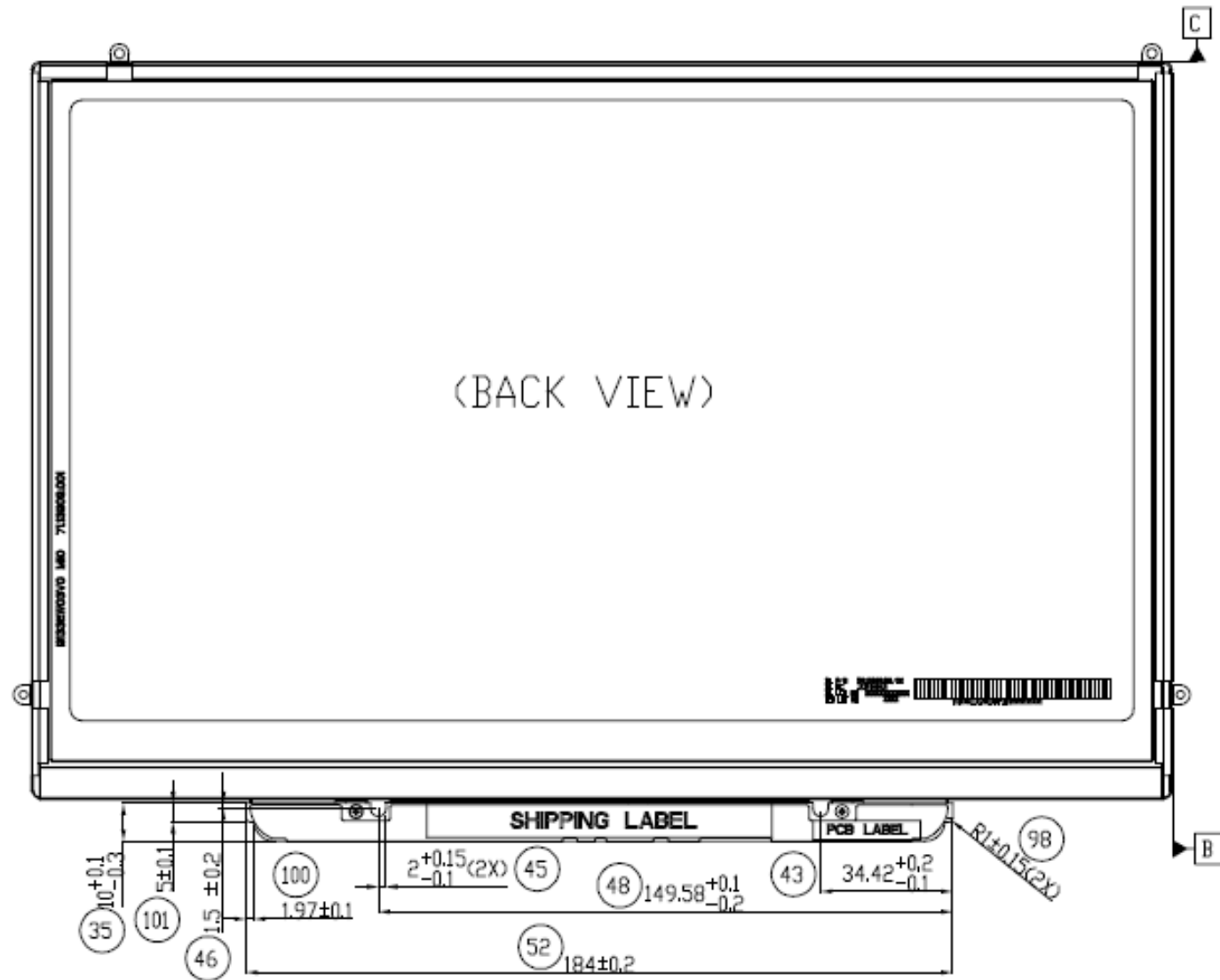



# Product Specification

AU OPTRONICS CORPORATION

## 12. Shipping and Package

### 12.1 Shipping Label Format

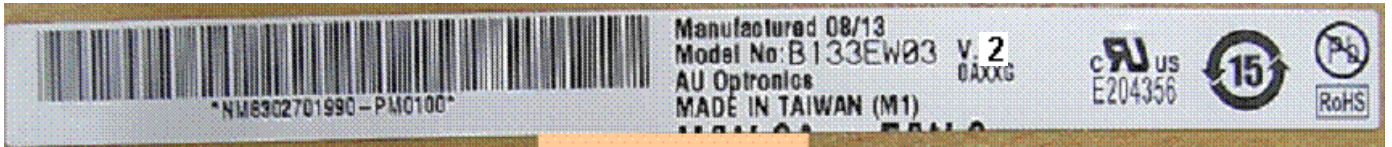

## 12.2 Carton package

The outside dimension of carton is 435 (L)mm x 377 (W)mm x 335 (H)mm



## 11.3 Shipping package of palletizing sequence

